



Voice Communication Systems

System Overview

The fully digital, non-blocking Gemini Range of VCS Systems-with variable bandwidth TDM (Time Division Multiplex) Technology is designed for all ATC applications

- Small Tower Voice Switch – Digital (STVS-D) is specifically designed for small airports that up till now could not afford modern integrated, VCS Systems. STVS-D is also ideal for Ramp Control and back-up communications applications
- Tower Voice Switch (TVS) is designed for medium and large size towers, as well as for approach controls. TVS can also be used in small Area Control Centres
- Area Control Centre Voice Switch (ACCVS) is designed for even the largest Centres. ACCVS can also be used for Airline Command and Operations Centres well as for a wide variety of military command ,Control and Communications Applications

Adding further system cards can expand both ACCVS and TVS Systems. This can be done without requiring additional software licenses or upgrade licenses

Drake's proven star-point architecture eliminates risk of interconnection failures experienced with ring or loop based systems and uses standard interfaces for both internal and external communications

Regardless of application, Gemini provides system availability of > 0.999995 with comprehensive dual switch redundancy that can support narrow bandwidth (3.4Khz) or wide bandwidth (7.4Khz) voice processing, with low noise performance. By using a high TDM Sampling rate, all audio signals have maximum intelligibility.

Fully Redundant and hot-swappable power supplies, processor and switching elements ensure that a fail-safe operation is maintained at all times.

Two Unique software programs perform Gemini's System Control Terminals (SCT) Functions. The system management software (CMAPSi) is a powerful and flexible tool for reconfiguration and assignment of assets. The diagnostics and monitoring software (ADM) detects and reports failure of key redundant Line Replaceable system elements, before service is affected. Drake can provide this software already loaded on suitable Windows Platform, alternatively Drake can provide CMAPSi and ADM for loading on suitable PC's already in customer inventory

Connection to radios, external equipment and communication networks is available
Via wide range of standard interfaces that include

- Analogue Telephone (4 wire & 2-wire with hardware signaling)
- ISDN (G.711,G.722,G.728)
- X.21
- Analogue Radio

Over a Range of Media

- Co-Axial
- CAT 5
- Optical Fibre

Gemini also supports multi channel, disc-based digital voice recording, either locally or centrally

DUAL REDUNDANT ARCHITECTURE

- Gemini Technology employs dual audio matrix core with two active parallel audio paths between any operator station and each radio and/or lines interface
- Audio matrix cores can be installed in separate locations to enhance system resilience
- N+N Redundancy => 0.999995 Availability

N+N=>. 999995

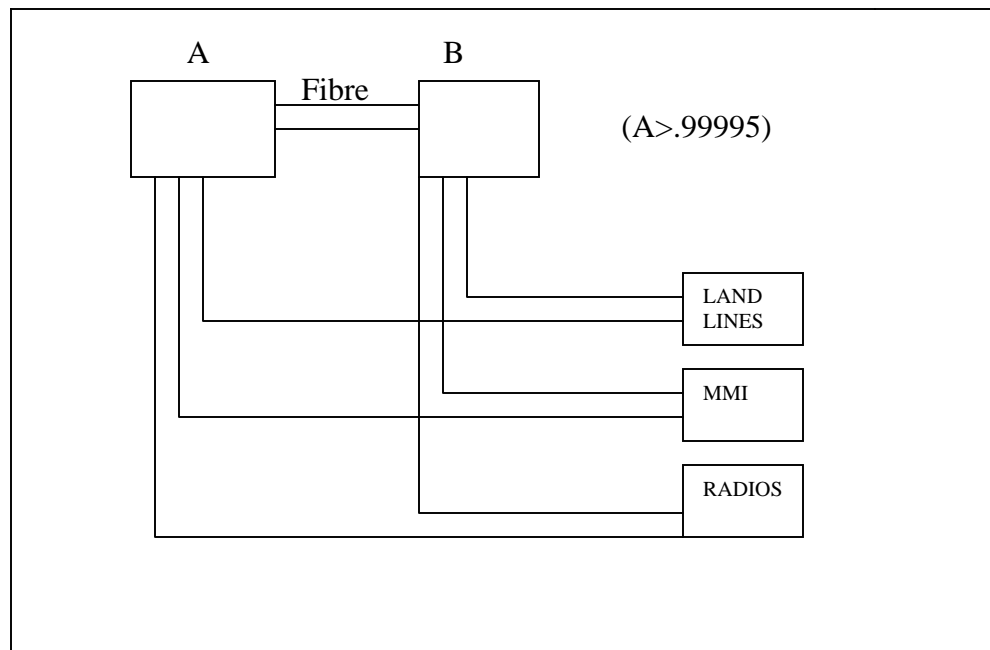

Flexible Touch Input Devices (TIDs)

Drake's range of TIDs provide full customer flexibility in formatting of key colours , sizing, positioning and numbers ,with exceptional voice transmission quality . The operators may adjust the displays for a large range of ambient light conditions encountered in Tower, Approach and Centre operations. The greater viewing angle achieved in the display subsystem has now eliminated the need for complex tilting panel mounting hardware

Drake's standard multiple page TID provides user access to radio's, telephones and special functions typically used by ATC personnel

Each TID provides ATC Controllers with a fast, flexible user interface, available in a variety of screen sizes from 140mm to 717mm. TIDs also feature in built power supply redundancy with comprehensive monitoring and alarm facility.

Local, National or Global Networking Capabilities

Drake's new modular VeNIX unit offers a Voice, Ethernet, Networking, ISDN and X.21 communications solution in one compact rack mounted device, either in 1 RU or 3 RU format chassis. The VeNIX unit enables VCS System networking, connection to remote operator panels and direct connection to public, private or leased line telephone networks.

The VeNIX unit is an ideal platform for integration of voice and data communications